

200 SERIES PUMP WITH INTEGRATED ELECTRONICS

The Lee Company introduces the latest addition to our radial piston pump product line – the Lee 200 Series Pump with an integrated drive. This design combines the performance of our 200 series positive displacement pump with the convenience of electronics for precise motor control.

The 200 Series Pump provides high flow and pressure capabilities in a small package. The pump is supplied with a powerful brushless DC servo motor and equipped with an integrated drive unit while still only weighing two pounds. It can provide 200 pounds per hour of flow at pressures as high as 100 psid. Qualified for 1000 hours of operation and to numerous aerospace specifications, this pump offers excellent durability and efficiency.

Please contact your local Lee Sales Engineer for additional information and technical assistance.

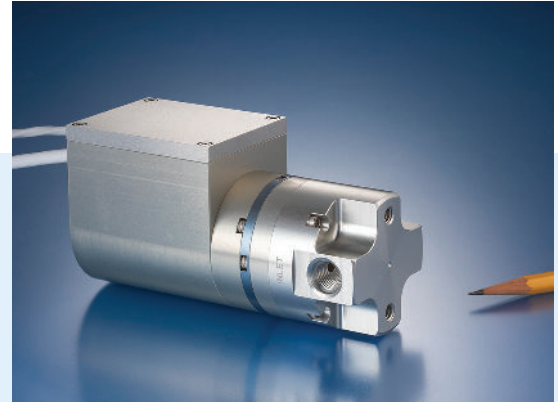

- Self-priming
- 100% tested and inspected
- 12-36 VDC supply voltage
- Status feedback includes pump speed, motor current, and fault monitoring
- Variable speed for optimal efficiency under varying conditions
- Compatible with most fuels and petroleum-based fluids
- -40°F to 212°F operating temperature range
- Custom designs with expanded temperature ranges available
- Wetted Materials: 7075 Anodized Aluminum, Fluorosilicone, 15-5PH CRES, 17-7PH CRES, 400 Series CRES, 300 Series CRES, PTFE, Phenolic, and Nickel Aluminum Bronze

Lee Part Number GPRA2001511C

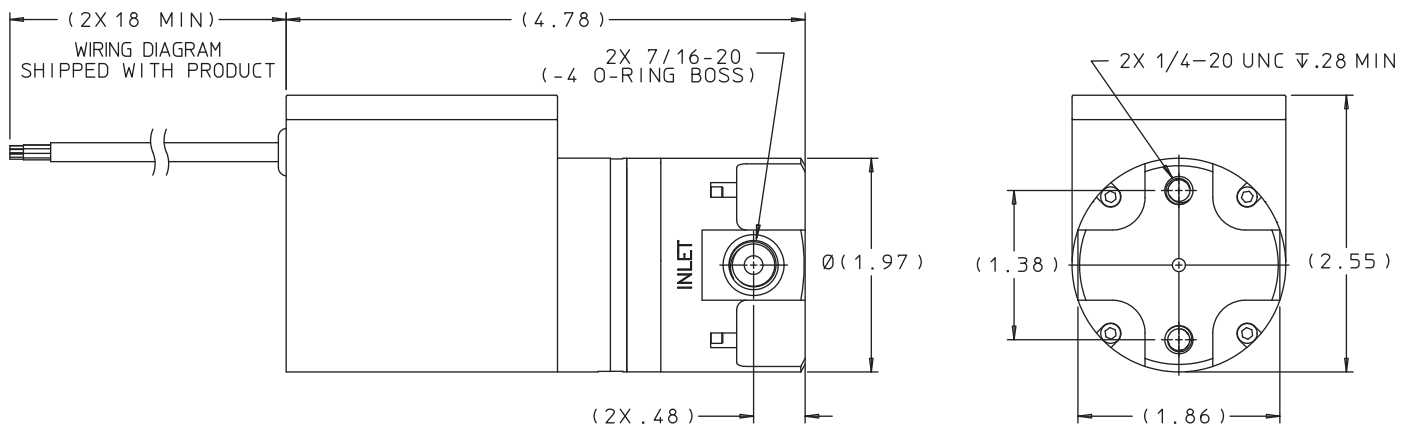

PERFORMANCE DATA

Nominal Flow:.....	0.52 GPM MIL-PRF-7024 Type II at 70°F – 80°F (200 PPH)
Maximum Pressure Rise:	100 psid
Speed Command Voltage:.....	2.5 - 8.0 VDC (2050 - 6560 RPM)
Temperature Range:.....	-40°F to 212°F
Supply Voltage:.....	12 – 36 VDC
Nominal Power Required at 100 psid and 0.52 GPM:.....	.65 W



200 SERIES PUMP WITH INTEGRATED ELECTRONICS

FLOW

TYPICAL PERFORMANCE AT 70° - 80°F WITH MIL-PRF-7024 TYPE II

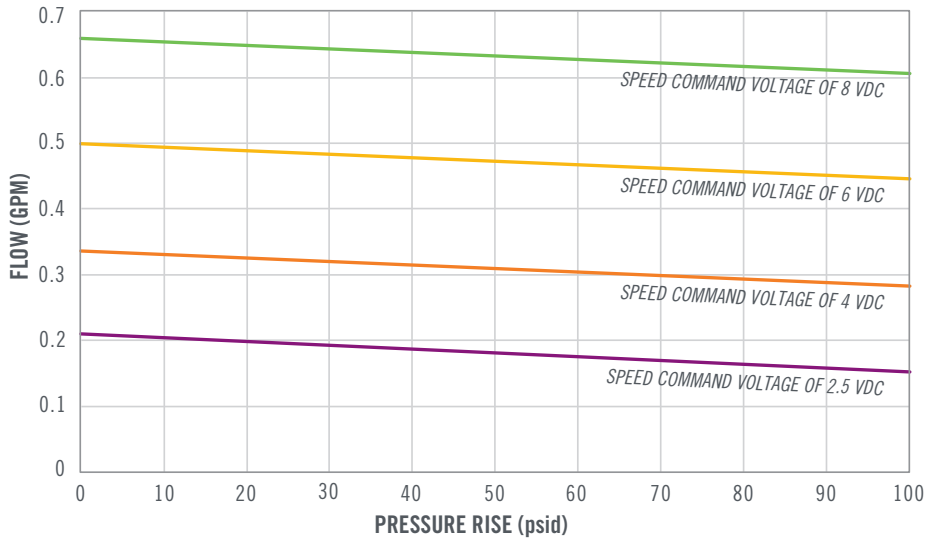

SUPPLY CURRENT AND POWER

TYPICAL PERFORMANCE AT 70° - 80°F WITH MIL-PRF-7024 TYPE II

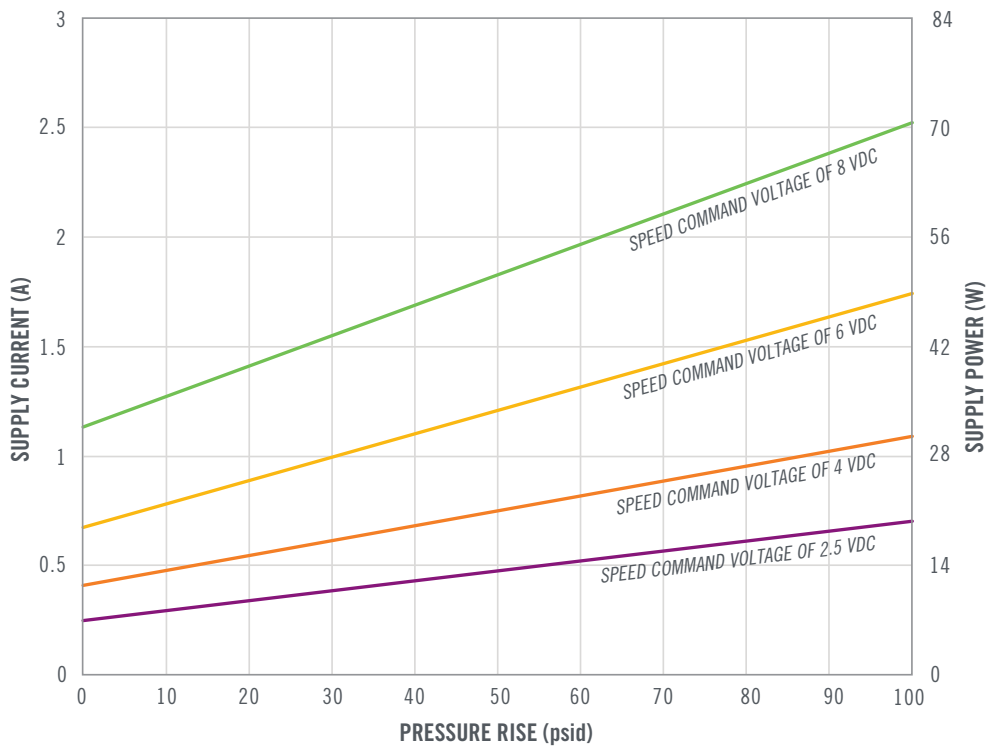

QUALIFICATION TESTING

RTCA/DO-160D	Environmental Conditions and Test Procedures for Airborne Equipment
SAE ARP8615	General Specification for Fuel System Components
SAE AIR4246	Contaminant for Aircraft Turbine Engine Fuel System Component Testing
MIL-STD-810	Environmental Test Methods

