

281 ZERO LEAK PRI®

The Lee Company's new 281 Zero Leak PRI (Pressure Relief Insert) is the latest addition to Lee's line of miniature pressure relief valves. This new valve is ideal for thermal relief and low flow hydraulic pressure relief applications where zero leakage is needed.

The cracking pressure is preset at the factory with capabilities ranging from 800 psid up to 4700 psid. Typical flow rates range from a few mL's per minute for thermal relief applications, and up to 0.5 GPM for low flow pressure relief applications. Each Zero Leak PRI is 100% tested and inspected to ensure reliable, consistent performance.

Please contact your local Lee Sales Engineer for assistance in solving your zero leak relief valve needs.

- Cracking Pressure from 800 - 4700 psid
- Zero Leakage in a One Minute Test; One Drop Per Hour Maximum
- Weighs only 6 grams
- Working Temperature from -65°F to +275°F
- 100% Tested and Inspected
- Endurance Tested to 100,000 Cycles Minimum

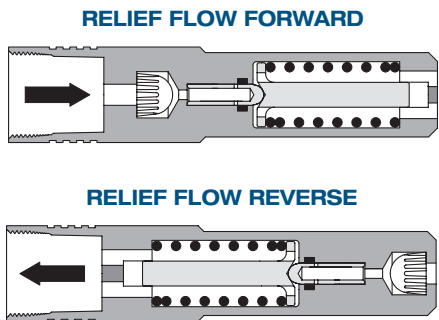

MATERIALS		
PART	MATERIAL	SPECIFICATION
Body	15-5PH CRES	AMS 5659
Pin	15-5PH CRES	AMS 5659
Poppet	440C CRES	AMS 5630
Seal	Polymer	—
Poppet Guide	303 CRES	QQ-S-763C
Retainers	303 CRES	QQ-S-763C
Spring Guide	303 CRES	QQ-S-763C
Spring Seat	303 CRES	QQ-S-763C
Spring	17-7PH CRES	AMS 5678
Screen	304L CRES	ASTM A 666
Braze	—	AMS 4774

Finish: All CRES Parts Passivated.
 Pins are prewaxed. Do not degrease. Do not lubricate.

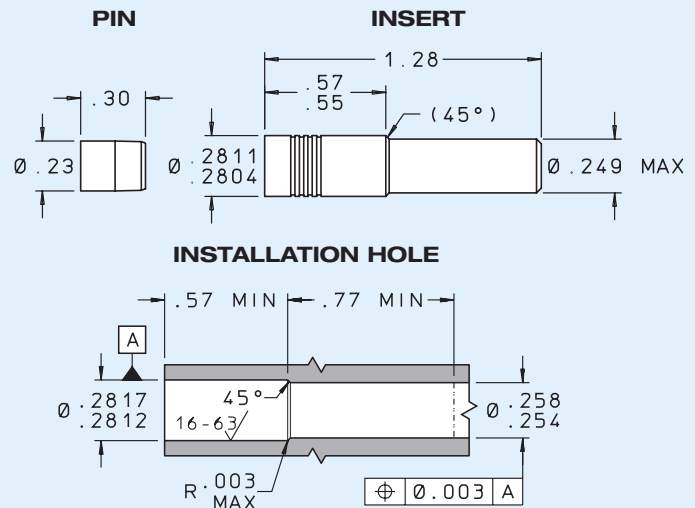

LEE PART NUMBER		MINIMUM CRACKING PRESSURE (psid)	FLOW POINT			MINIMUM SHUTOFF PRESSURE (psid)
FORWARD	REVERSE		LOHM* RATE	MIN. FLOW (ml/min.)	AT (psid)	
PSFA2813800L	PSRA2813800L	800	100,000	25	930	660
PSFA2813130D	PSRA2813130D	1300	100,000	33	1500	1100
PSFA2813250D	PSRA2813250D	2500	100,000	45	3000	2100
PSFA2813350D	PSRA2813350D	3500	100,000	55	4050	3100
PSFA2813470D	PSRA2813470D	4700	100,000	63	5400	4100

PERFORMANCE	
Leakage at Minimum Cracking Pressure:	Zero drops in a one minute test; 1 drop/hour maximum
Leakage at Minimum Shutoff Pressure:	Zero drops in a one minute test; 1 drop/hour maximum
Nominal System Pressure:4000 psi maximum
System Peak Pressure:5400 psi maximum
Screen Hole Size:004" nominal
Valve performance on MIL-PRF-83282 or MIL-PRF-5606 at 85°F ± 15°F	

*The Lohm is a measure of flow resistance. Additional information can be found on the reverse side and at www.TheLeeCo.com.

LEE LOHM LAWS

LOHMS LAWS (liquids)

Every engineer will be interested in our simple system of defining the fluid resistance of Lee hydraulic components.

Just as the OHM is used in the electrical industry, we find that we can use a liquid OHM or "Lohm" to good advantage on all hydraulic computations.

When using the Lohm system, you can forget about coefficients of discharge and dimensional tolerances on drilled holes. These factors are automatically compensated for in the Lohm calculations, and confirmed by testing each component to establish flow tolerances. The resistance to flow of any fluid control component can be expressed in Lohms.

The Lohm has been selected so that a 1 Lohm restriction will permit a flow of 100 gallons per minute of water with a pressure drop of 25 psi at a temperature of 80°F.

LIQUID FLOW FORMULA

The following formulas are presented to extend the use of the Lohm laws to many different liquids, operating over a wide range of pressure conditions.

These formulas introduce compensation factors for liquid density and viscosity. They are applicable to any liquid of known properties, with minimum restrictions on pressure levels or temperature.

The units constant (K) eliminates the need to convert pressure and flow parameters to special units.

$$\text{Volumetric Flow Units } L = \frac{KV}{I} \sqrt{\frac{H}{S}} \quad \text{Gravimetric Flow Units } L = \frac{KV}{w} \sqrt{HS}$$

LIQUID FLOW - UNITS CONSTANT K

VOLUMETRIC FLOW UNITS			
Flow Units	Pressure Units		
	psi	bar	kPa
GPM	20	76.2	7.62
L/min	75.7	288	28.8
ml/min	75 700	288 000	28 800
in ³ /min	4 620	17 600	1 760

GRAVIMETRIC FLOW UNITS			
Flow Units	Pressure Units		
	psi	bar	kPa
PPH	10 000	38 100	3810
gm/min	75 700	288 000	28 800

NOMENCLATURE

- L = Lohms
- S = Specific gravity*
- H = Differential pressure
- V = Viscosity compensation factor**
- I = Liquid flow rate: Volumetric
- w = Liquid flow rate: Gravimetric
- K = Units Constant – Liquid (see chart below)
- *S = 1.0 for water at 80°F.
- **V = 1.0 for water at 80°F.

For other fluids and temperatures, contact your Lee Sales Engineer or visit us at www.TheLeeCo.com.