

687 SIDE EXIT PRV

The Lee Company's new 687 Side Exit PRV is the latest addition to Lee's line of field proven Pressure Relief Valves. This new valve is ideally suited for hydraulic applications where a fast opening safety relief valve is needed to prevent system damage from pressure spikes.

Offered with or without an integral safety screen, the 687 PRV is available in a range of minimum cracking pressures from 400 to 3600 psid. Each Lee Pressure Relief Valve is 100% tested and inspected to ensure reliable, consistent performance.

- Cracking Pressures from 400 to 3600 psid
- Inlet Safety Screen Available
- Designed for System Proof Pressures up to 4500 psi
- Weighs Only 39 Grams
- Endurance Tested to 100,000 Cycles Minimum

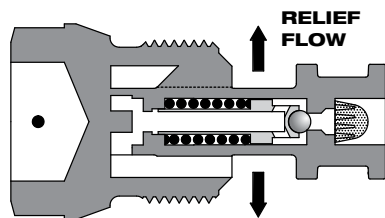

(Shown with available Safety Screen)

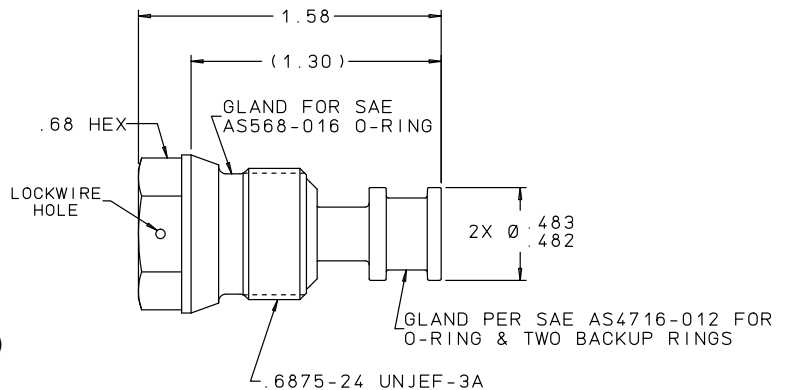

PERFORMANCE	
Leakage at Minimum Cracking Pressure:	1 mL/min maximum
Leakage at Minimum Shutoff Pressure:	1 mL/min maximum
Restriction at Minimum Recommended Valve Lift:	1500 Lohms
Nominal System Pressure:	up to 3000 psi
System Proof Pressure:	4500 psi maximum
Nominal Weight:	38 grams (unscreened) 39 grams (screened)
Valve performance on MIL-PRF-83282 or MIL-PRF-5606 at 85° F +/- 15° F	

LEE PART NUMBER	MINIMUM CRACKING PRESSURE (psid)	FLOW POINT (MIL-PRF-83282)			MINIMUM SHUTOFF PRESSURE (psid)
		MAX. LOHM RATE	MIN FLOW (GPM)	AT (psid)	
687 Side Exit PRV					
PRVA0687140 D	400	230	2.0	500	340
PRVA0687160 D	600	230	2.5	750	510
PRVA0687112 H	1200	230	3.6	1500	1020
PRVA0687116 H	1600	230	4.2	2000	1360
PRVA0687122 H	2200	230	5.0	2750	1870
PRVA0687126 H	2600	230	5.4	3250	2210
PRVA0687132 H	3200	280	4.8	4000	2720
PRVA0687136 H	3600	280	5.1	4500	3060
Screened 687 Side Exit PRV					
PRVA0687340 D	400	300	1.6	500	340
PRVA0687360 D	600	300	1.9	750	510
PRVA0687312 H	1200	300	2.7	1500	1020
PRVA0687316 H	1600	300	3.2	2000	1360
PRVA0687322 H	2200	300	3.7	2750	1870
PRVA0687326 H	2600	300	4.0	3250	2210
PRVA0687332 H	3200	350	3.8	4000	2720
PRVA0687336 H	3600	350	4.1	4500	3060

687 SIDE EXIT PRV

INSTALLATION HOLE

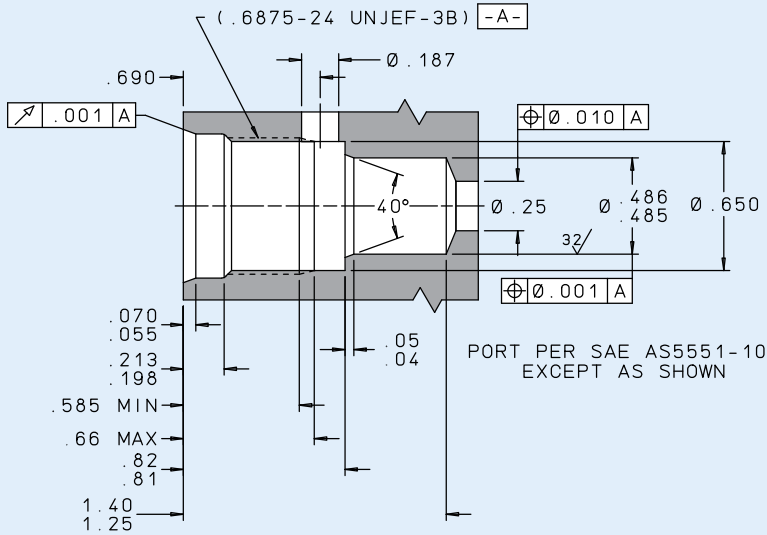

MATERIALS		
PART	MATERIAL	SPECIFICATION
Body	303 CRES	QQ-S-763C
Spring Seat	303 CRES	QQ-S-763C
Seat	303 CRES	QQ-S-763C
Retainer	303 CRES	QQ-S-763C
Ball Follower	303 CRES	QQ-S-763C
Spring	17-7PH CRES	AMS 5678
Tube	304 CRES	AMS 5639
Ball	440C CRES	AMS 5630
Screen*	304L CRES	ASTM A 666
Braze*	—	AMS 4774

* For screened valves.

LEE LOHM LAWS

LOHMS LAWS (liquids)

Every engineer will be interested in our simple system of defining the fluid resistance of Lee hydraulic components.

Just as the OHM is used in the electrical industry, we find that we can use a liquid OHM or "Lohm" to good advantage on all hydraulic computations.

When using the Lohm system, you can forget about coefficients of discharge and dimensional tolerances on drilled holes. These factors are automatically compensated for in the Lohm calculations, and confirmed by testing each component to establish flow tolerances. The resistance to flow of any fluid control component can be expressed in Lohms.

The Lohm has been selected so that a 1 Lohm restriction will permit a flow of 100 gallons per minute of water with a pressure drop of 25 psi at a temperature of 80°F.

LIQUID FLOW FORMULA

The following formulas are presented to extend the use of the Lohm laws to many different liquids, operating over a wide range of pressure conditions.

These formulas introduce compensation factors for liquid density and viscosity. They are applicable to any liquid of known properties, with minimum restrictions on pressure levels or temperature.

The units constant (K) eliminates the need to convert pressure and flow parameters to special units.

$$\text{Volumetric Flow Units } L = \frac{KV}{I} \sqrt{\frac{H}{S}} \quad \text{Gravimetric Flow Units } L = \frac{KV}{w} \sqrt{HS}$$

LIQUID FLOW - UNITS CONSTANT K

VOLUMETRIC FLOW UNITS			
Flow Units	Pressure Units		
	psi	bar	kPa
GPM	20	76.2	7.62
L/min	75.7	288	28.8
ml/min	75 700	288 000	28 800
in ³ /min	4 620	17 600	1 760

GRAVIMETRIC FLOW UNITS			
Flow Units	Pressure Units		
	psi	bar	kPa
GPM	10 000	38 100	38 10
in ³ /min	75 700	288 000	28 800

NOMENCLATURE

- L = Lohms
- S = Specific gravity*
- H = Differential pressure
- V = Viscosity compensation factor**
- I = Liquid flow rate: Volumetric
- w = Liquid flow rate: Gravimetric
- K = Units Constant - Liquid (see chart)

*S = 1.0 for water at 80°F.

**V = 1.0 for water at 80°F.

For other fluids and temperatures, contact your Lee Sales Engineer or visit us at www.theleeco.com.